

Key



**Grade 7
Common Mathematics Assessment**

June 12, 2013

Section A: No Calculator Permitted

Name: _____

Mathematics Teacher: _____

Homeroom: _____

IMPORTANT

You will need to complete your name and school information in three places:

1. Section A
2. Section B
3. Answer Sheet

Section A: No Calculator Permitted

16 Selected Response	16 points
7 Constructed Response	16 points
Total	32 points

Section B: Calculator Permitted

24 Selected Response	24 points
9 Constructed Response	24 points
Total	48 points

FINAL

80 POINTS

Selected Response: No Calculator Permitted.

For items 1 – 16, circle the appropriate response on the answer sheet.

1. Which Venn diagram correctly shows the divisibility rules for 3 and 4?

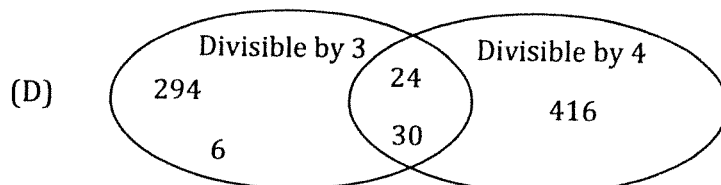
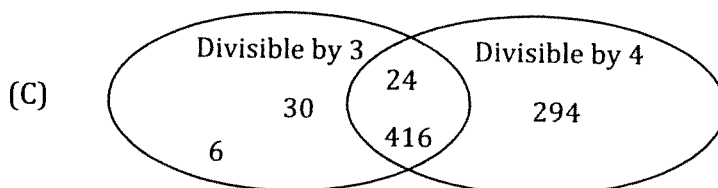
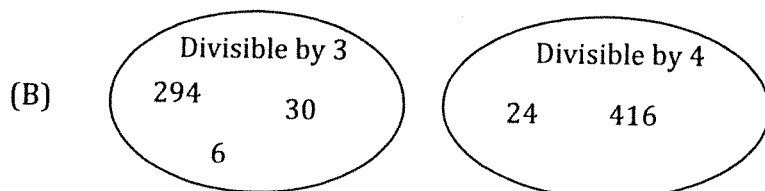
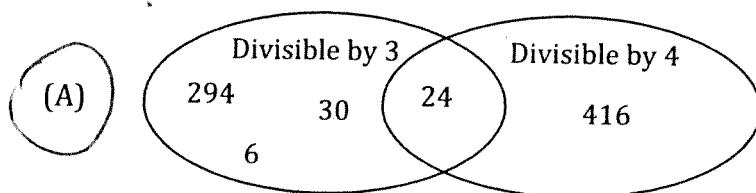

2. Which describes the algebraic expression $5n + 2$?

- (A) A number is doubled and increased by 5.
(B) Half a number is increased by 5.
(C) Five times a number is increased by 2.
(D) One-fifth of a number is increased by 2.

3. Which represents 8°C cooler than -3°C ?

- (A) $(-8) - (-3) = (-5)$
(B) $(-3) - (-8) = (+5)$
(C) $(+8) - (-3) = (+11)$
(D) $(-3) - (+8) = (-11)$

4. Calculate: $(+5) + (-9)$

- (A) -14
(B) -4
(C) 4
(D) 14

Grade 7 Common Mathematics Assessment
Section A

5. Which represents $(+2)$?
- (A) $\oplus \ominus$
- (B) $\oplus \oplus \ominus$
- (C) $\oplus \oplus \ominus \ominus \ominus \ominus$
- (D) $\oplus \oplus \oplus \oplus \ominus \ominus$
6. Which represents (-2) ?
- (A) An elevator goes up 6 floors and then down 2 floors.
- (B) Walk 4 steps forward and 6 steps back.
- (C) The temperature rises 8°C from -2°C .
- (D) Getting an allowance of \$12 is followed by spending \$10.
7. What is $\frac{3}{20}$ as a percent?
- (A) 3%
- (B) 6%
- (C) 12%
- (D) 15%
8. Which is between $\frac{3}{5}$ and 0.8 ?
- (A) 0.4 0.6
- (B) 0.6
- (C) $\frac{7}{10}$
- (D) $\frac{4}{5}$
9. Which represents front end estimation for the product 8.3×13.7 ?
- (A) $8 \times 13 = 104$
- (B) $8 \times 14 = 112$
- (C) $9 \times 13 = 117$
- (D) $9 \times 14 = 126$
10. Which has a repeating decimal?
- (A) $\frac{8}{25}$
- (B) $\frac{2}{5}$
- (C) $\frac{1}{2}$
- (D) $\frac{2}{3}$

Grade 7 Common Mathematics Assessment
Section A

11. Write in order from least to greatest: $\frac{13}{10}$, 0.35, 1, $1\frac{4}{9}$

(A) 0.35, 1, $1\frac{4}{9}$, $\frac{13}{10}$

(B) 0.35, 1, $\frac{13}{10}$, $1\frac{4}{9}$

(C) 0.35, $\frac{13}{10}$, 1, $1\frac{4}{9}$

(D) $1\frac{4}{9}$, 1, $\frac{13}{10}$, 0.35

1.3 0.35 1 1. $\overline{4}$

0.35 1 1.3 1. $\overline{4}$

0.35 1 $\frac{13}{10}$ $1\frac{4}{9}$

12. Which is modelled below?

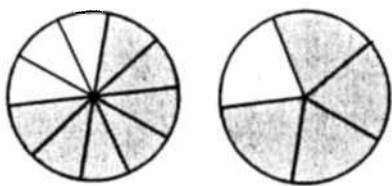

(A) $\frac{7}{10} + \frac{4}{5} = \frac{11}{15}$

(B) $\frac{7}{10} + \frac{4}{5} = \frac{11}{10} = 1\frac{1}{10}$

(C) $\frac{7}{10} + \frac{4}{5} = \frac{15}{10} = 1\frac{1}{2}$

(D) $\frac{7}{10} + \frac{4}{5} = \frac{11}{5} = 2\frac{1}{5}$

13. Which is modelled below?

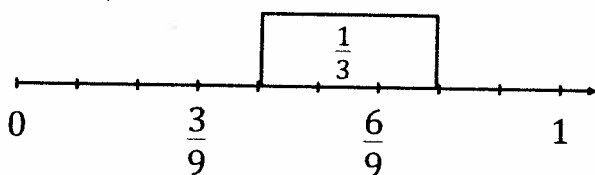

(A) $\frac{1}{3} - \frac{4}{9} = \frac{7}{9}$

(B) $\frac{1}{3} - \frac{7}{9} = \frac{4}{9}$

(C) $\frac{4}{9} - \frac{1}{3} = \frac{7}{9}$

(D) $\frac{7}{9} - \frac{1}{3} = \frac{4}{9}$

$\frac{7}{9} - \frac{1}{3} = \frac{4}{9}$
 $\frac{7}{9} - \frac{3}{9}$ (with an arrow pointing to the result)

14. A student did not receive full marks for her solution below. In which step did she make her **first** error?

$$2\frac{4}{7} - 1\frac{1}{3}$$

$$\text{Step 1} = \frac{18}{7} - \frac{4}{3}$$

$$\text{Step 2} = \frac{14}{4}$$

$$\text{Step 3} = 3\frac{2}{4}$$

$$\text{Step 4} = 3\frac{1}{2}$$

- (A) 1
(B) 2
(C) 3
(D) 4

15. Lisa spent $\frac{2}{3}$ hour doing homework in the morning and $\frac{2}{15}$ hour doing homework in the afternoon. What fraction of an hour did she spend doing homework?

(A) $\frac{2}{9}$

(B) $\frac{4}{15}$

(C) $\frac{8}{15}$

(D) $\frac{4}{5}$

$$\frac{2}{3} + \frac{2}{15} = \frac{10}{15} + \frac{2}{15} = \frac{12}{15} = \frac{4}{5}$$

16. Noel and his friends shared an orange that was separated into 8 equal pieces. Noel ate 1 piece, one friend ate 2 pieces, and the other friend ate 4 pieces. What fraction of the orange is left?

(A) $\frac{0}{8}$

(B) $\frac{1}{8}$

(C) $\frac{7}{8}$

(D) $\frac{8}{8}$

Constructed Response: No Calculator Permitted.

Answers to be written on this paper in the space provided. Show all workings.

17. Name **two pairs** of integers that have a difference of (-1) and write each subtraction statement. [2 points]

(+6)	(+5)
	(-8)
(-5)	(-9)
	(+8)

$$(+5) - (+6) = -1 \quad (1)$$

$$(-9) - (-8) = -1 \quad (1)$$

18. A submarine was 10 m below sea level when the captain spotted a whale 8 m below him. [2 points]

- a) Write an **addition** equation to determine the distance the whale was below the surface of the water.

$$d = (-10) + (-8) \quad (1)$$

- b) Solve the equation using a method of your choice.

$$\begin{aligned} \text{distance} &= (-10) + (-8) \\ &= (-18) \end{aligned} \quad (1)$$

The whale was 18m below the surface.

19. Explain why 60% is **not** a good estimate for 35 out of 80. [2 points]

Since $35/80$ is less than half, the % should be less than 50%. (1)

Grade 7 Common Mathematics Assessment
Section A

20. Calculate: $1.5 + 6.6 \div (0.4 + 2.6)$

[3 points]

$$\begin{aligned} &= 1.5 + 6.6 \div (3.0) \quad \textcircled{1} \\ &= 1.5 + 2.2 \quad \textcircled{1} \\ &= 3.7 \quad \textcircled{1} \end{aligned}$$

21. Janet's lunch bill at a restaurant was \$25.00, tax included. She decided to leave a 15% tip.

[2 points]

a) Calculate how much she left for a tip.

$$15\% \text{ of } 25.00$$

$$\begin{array}{r} = \quad 25.00 \\ \quad \times 0.15 \\ \hline \quad 12500 \\ \quad 2500 \\ \hline \quad 3.7500 \end{array}$$

$$\text{Tip} = \$ 3.75 \quad \textcircled{1}$$

b) Calculate the total cost of her lunch.

$$\begin{array}{r} \text{Total Cost} = \$25.00 \\ \quad + 3.75 \\ \hline \quad \$ 28.75 \end{array} \quad \textcircled{1}$$

22. Two people shared **one** pizza. Which statement below is true?

[2 points]

Model each situation to explain your thinking.

Statement A: Angela ate $\frac{3}{4}$ and Drew ate $\frac{3}{8}$.

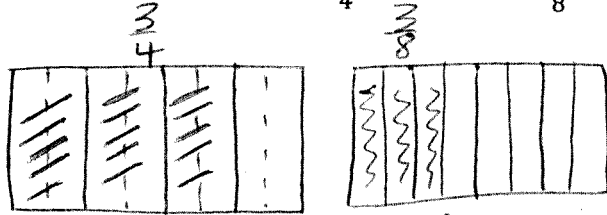

①

Statement B:

Angela ate $\frac{7}{12}$ and Drew ate $\frac{1}{3}$.

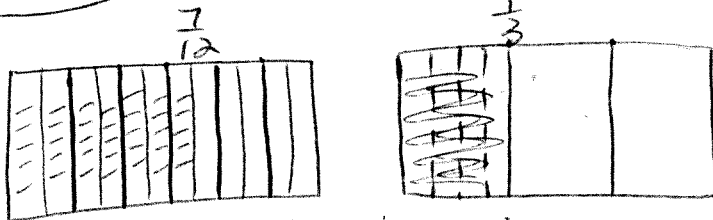

①

True

$\frac{3}{8}$ is too big to fit into the remaining $\frac{1}{4}$ (or $\frac{2}{8}$), so it would be more than one pizza.

$\frac{1}{3}$ (or $\frac{4}{12}$) will fit with the $\frac{7}{12}$ to make less than 1 pizza.

23. Calculate: $2\frac{1}{6} - 1\frac{3}{4} + \frac{1}{2}$

[3 points]

$$= \textcircled{1} 2\frac{2}{12} - 1\frac{9}{12} + \frac{6}{12}$$

$$= \textcircled{1} \frac{26}{12} - \frac{21}{12} + \frac{6}{12}$$

$$= \textcircled{\frac{1}{2}} \frac{5}{12} + \frac{6}{12}$$

$$= \textcircled{\frac{1}{2}} \frac{11}{12}$$

OR

$$\frac{13}{6} - \frac{7}{4} + \frac{1}{2}$$

End of Section A.

Please raise your hand and your teacher will collect Section A.

You may now begin Section B.



**Grade 7
Common Mathematics Assessment**

June 12, 2013

Section B: Calculator Permitted

Name:

Mathematics

Teacher:

Homeroom:

Section A: No Calculator Permitted

16 Selected Response	16 points
7 Constructed Response	16 points
Total	32 points

Section B: Calculator Permitted

24 Selected Response	24 points
9 Constructed Response	24 points
Total	48 points

FINAL

80 POINTS

Selected Response: Calculator Permitted.

For items 24 - 47, circle the appropriate response on the answer sheet.

24. Evaluate $\frac{c}{2} - 8$ for $c = 20$.

- (A) 2
- (B) 6
- (C) 18
- (D) 32

$$\frac{20 - 8}{2} = 10 - 8$$

25. Which algebraic expression has a numerical coefficient of 6?

- (A) $a + 6 + 12$
- (B) $6b + 12$
- (C) $c + 6$
- (D) $2 - 6d$

26. Which describes the relationship between the diagram number (d), and the number of toothpicks (t)?

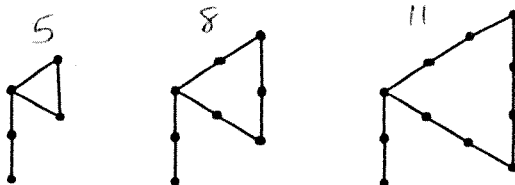

Diagram #1 Diagram #2 Diagram #3

- (A) $d = 3t$
- (B) $d = 3t + 2$
- (C) $t = 3d$
- (D) $t = 3d + 2$

27. Out of 350 students at a junior high school, 80% participate in the breakfast program. How many students participate?

- (A) 70
- (B) 80
- (C) 270
- (D) 280

$$80\% \times 350 = \frac{350 \times 80}{100} = 280.0$$

28. How many 0.6 L glasses can be filled from a 1.8 L jug of lemonade?

- (A) 1
- (B) 2
- (C) 3
- (D) 4

$$0.6 \overline{) 1.8} \begin{array}{r} 3. \\ \underline{1.8} \\ 0 \end{array}$$

29. A circle has a radius of 8 cm. Estimate its area.

- (A) 24 cm^2
- (B) 48 cm^2
- (C) 64 cm^2
- (D) 192 cm^2

$$A = \frac{1}{2} \cdot r \cdot r \cdot 2 = 3 \cdot 8 \cdot 8$$

30. The area of a triangle is 24 cm^2 . What is the area of a parallelogram with the same base length and height as the triangle?

- (A) 12 cm^2
 (B) 24 cm^2
 (C) 48 cm^2
 (D) 75 cm^2

$$P = 2 \cdot \Delta = 2(24) = 48$$

31. The wheels on Brittney's bicycle have a diameter of 0.5 m . If she rides a total distance of 500 m , how many complete turns does the wheel make?

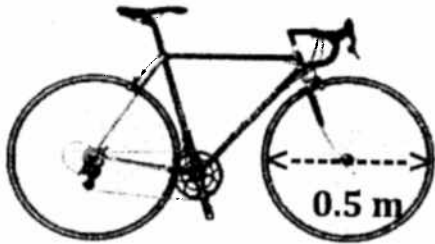

$$C = \pi \cdot d = 3.14(0.5) = 1.57$$

$$500 \div 1.57 = 318.47$$

- (A) 250
 (B) 318
 (C) 785
 (D) 1000

32. Jeff exercises 60 hours every month. How many **hours** does he spend swimming?

Jeff's Monthly Exercise

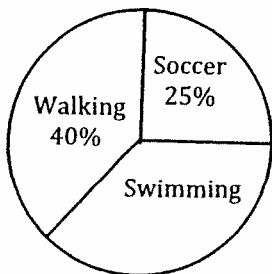

$$35\% \text{ of } 60 = \frac{.35}{60} = 21.00$$

- (A) 21
 (B) 27
 (C) 35
 (D) 39

33. The solution to finding the area of the given triangle is incorrect. In which step is the **first** error made?

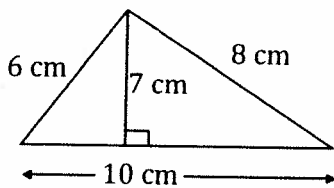

Step 1: $A = \frac{bh}{2}$

Step 2: $A = \frac{10 \text{ cm} \times 6 \text{ cm}}{2}$

Step 3: $A = \frac{60 \text{ cm}^2}{2}$

Step 4: $A = 30 \text{ cm}$

- (A) 1
 (B) 2
 (C) 3
 (D) 4

34. Calculate the area of parallelogram $ABCD$.

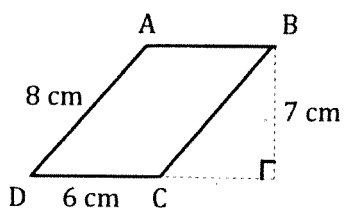

$$b \cdot h = 6 \cdot 7 = 42$$

- (A) 21 cm^2
 (B) 24 cm^2
 (C) 42 cm^2
 (D) 48 cm^2

35. What is the value of a ?

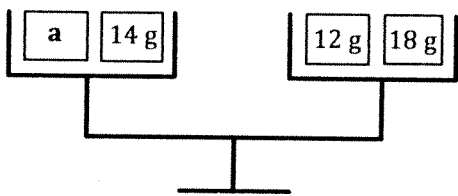

$$\begin{aligned} a + 14 &= 12 + 18 \\ a + 14 &= 30 \\ a &= 16 \end{aligned}$$

- (A) 14
 (B) 16
 (C) 30
 (D) 44

36. Which value of n makes the equation $3n - 4 = 8$ true?

- (A) 2
 (B) 3
 (C) 4
 (D) 5

$$\begin{aligned} 3n &= 8 + 4 \\ 3n &= 12 \\ n &= 4 \end{aligned}$$

37. Overnight the temperature dropped 7°C to -20°C . Which equation could be used to find the original temperature?

- (A) $t - 7 = (-20)$
 (B) $t + (-20) = 7$
 (C) $t - (-7) = (-20)$
 (D) $t + 20 = (-7)$

$$t - 7 = -20$$

38. Ricky worked h hours. Shawn worked twice as many hours as Ricky. If Shawn worked a total of 30 hours, which equation could be used to find the number of hours that Ricky worked?

- (A) $\frac{2}{h} = 30$
 (B) $\frac{h}{2} = 30$
 (C) $2h = 30$
 (D) $30h = 2$

R	S	
h	2h	$2h = 30$
	30	$\frac{2}{2} = \frac{30}{2}$

$$h = 15$$

Grade 7 Common Mathematics Assessment
Section B

39. Erin had a mean mark of 85% on her math tests this year. Then she received a grade of 92%. How did it affect the mean?

- (A) The mean increased.
- (B) The mean decreased.
- (C) There was no change in the mean.
- (D) The test was not used because it was an outlier.

40. What is the outlier in the given data set?

{28, 32, 32, 32, 38, 84, 36, 44, 42, 46}

- (A) 32
- (B) 46
- (C) 56
- (D) 84

41. On a tetrahedron with sides labelled 1 to 4, what is the probability of **not** rolling a 4?

- (A) 4%
- (B) 25%
- (C) 50%
- (D) 75%

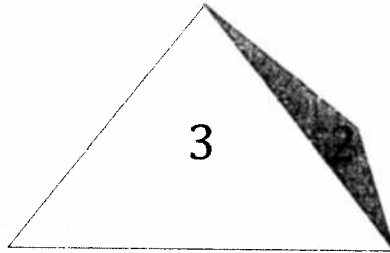

42. Kathy has three shirts that are yellow, purple, and blue, respectively. The shirts can be paired with jeans, dress pants, or a skirt. How many outfits can be created?

- (A) 3
- (B) 6
- (C) 9
- (D) 12

$$3(3) = 9 \quad \begin{matrix} Y \in \\ P \in \\ B \in \end{matrix}$$

43. Which transformation is demonstrated?

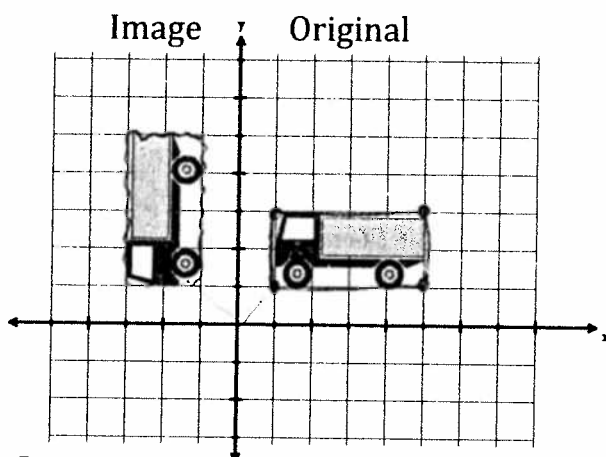

- (A) 90° CCW rotation about the origin
- (B) 90° CW rotation about the origin
- (C) reflection in the y-axis
- (D) translation 2 units left

44. What is a line that intersects another line at right angles and divides it into two equal parts?

- (A) angle bisector
- (B) parallel line
- (C) perpendicular bisector
- (D) perpendicular lines

45. Which statement is true?

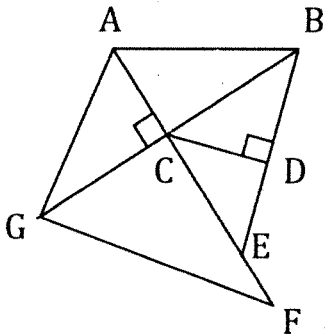

- (A) $\overline{AB} \parallel \overline{GB}$
- (B) $\overline{AB} \perp \overline{GF}$
- (C) $\overline{CD} \perp \overline{BE}$
- (D) $\overline{GB} \parallel \overline{AF}$

46. What are the coordinates of point P?

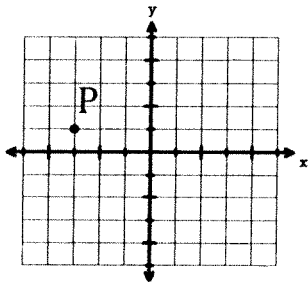

- (A) $(-3, -1)$
- (B) $(-3, 1)$
- (C) $(-1, -3)$
- (D) $(1, -3)$

47. Which is true?

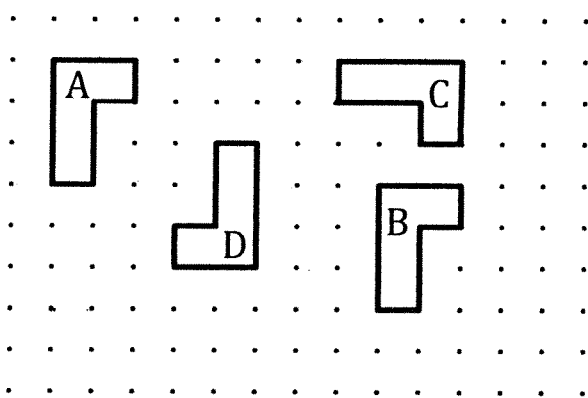

- (A) Figure A is a reflection of figure D.
- (B) Figure C is a 90° CCW rotation of Figure B.
- (C) Figure A is a translation of Figure B, 9 left and 3 up.
- (D) Figure B is a translation of Figure A, 8 right and 3 down.

Constructed Response: Calculator Permitted.

Answers to be written on this paper in the space provided. Show all workings.

48. Solve, using a method of your choice: $2n - 3 = 1$

[2 points]

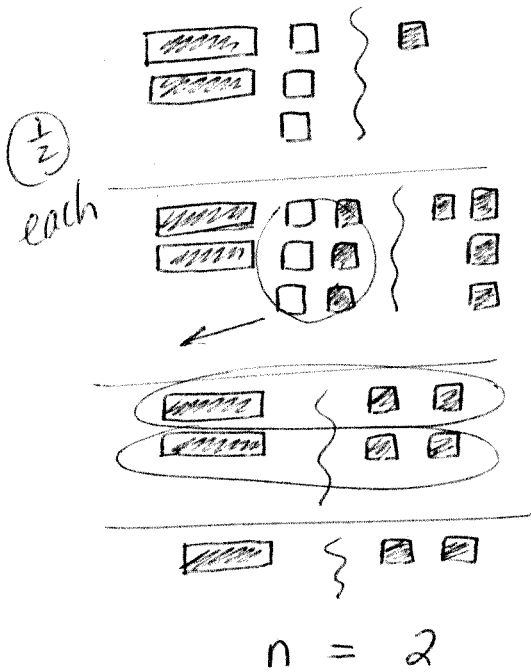

OR $2n - 3 = 1$

OR Systematic Trial.

① $2n - 3 + 3 = 1 + 3$

② $\frac{1}{2} \frac{2n}{2} = \frac{4}{2}$

③ $n = 2$

49. Eastern Junior High is ordering t-shirts for Pink Day. The t-shirt supplier charges a one-time fee of \$20 to create a logo and \$5 for each t-shirt purchased.

a) Complete the table: [1 point]

b) Graph the relation. Label the axes. [2 points]

①

Number of t-shirts (t)	Total Cost (c)
1	25
2	30
3	35
4	40

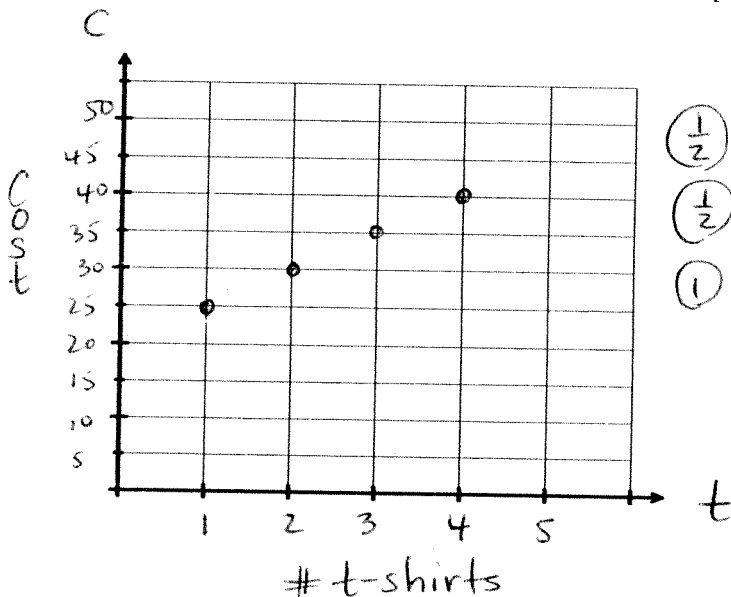

① labels
② scale
③ pts.

c) Write the equation for the cost of t-shirts and use it to calculate the total cost for 100 t-shirts. [2 points]

$C = 20 + 5t$ ①

$C = 20 + 5(100)$ ②

$C = \$520$ ③ Total cost for 100 t-shirts is \$520.

50. a) Solve algebraically: $\frac{x}{3} = 5$ [2 points]

$$\cancel{3} \cdot \frac{x}{\cancel{3}} = 3 \cdot 5 \quad \left(\frac{1}{2}\right)$$

$$x = 15 \quad \left(\frac{1}{2}\right)$$

- b) Verify your solution.

$$LS = \frac{x}{3}$$

$$= \frac{15}{3} \quad \left(\frac{1}{2}\right)$$

$$= 5 = RS \quad \left(\frac{1}{2}\right)$$

51. A grade 7 class surveyed 20 students to find out their favourite flavour of ice cream. They will use the data in the table to construct a circle graph. [2 points]

Flavour	# of Students	Fraction	Percent	Central Angle
Vanilla	9			
Chocolate	5			
Cookie Dough	6			
TOTAL	20			

Explain how to find the measure of the central angle for **Vanilla** only.

First find the fraction of students who like vanilla :

$$\left(\frac{1}{2}\right) \quad \frac{9}{20}$$

$\left(\frac{1}{2}\right)$ Then convert the fraction $\frac{9}{20}$ into a percent by writing an equivalent fraction out of 100 : $\frac{9}{20} = \frac{45}{100}$

$\left(\frac{1}{2}\right)$ Then multiply 45% by 360° to find the central angle : $45\% \times 360^\circ = 162^\circ$.

52. Nora flips a coin and spins a three-coloured spinner. Draw a tree diagram to show all possible outcomes. [2 points]

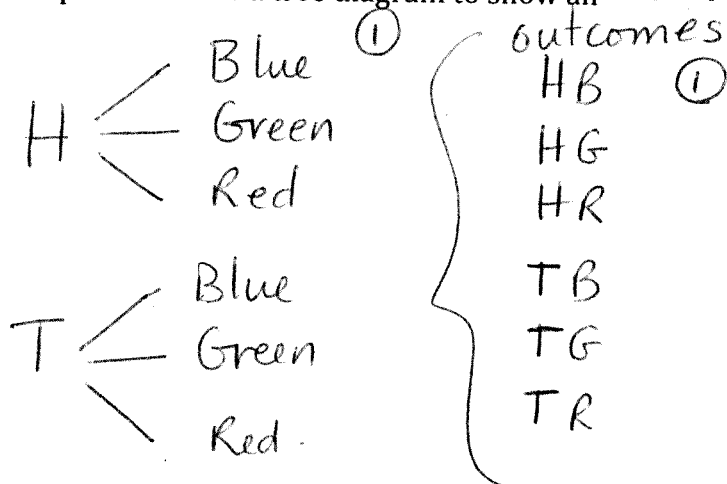
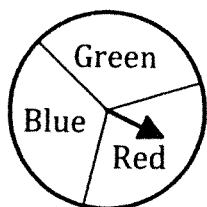
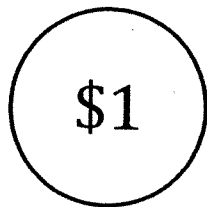

53. A 12 m by 18 m park has five identical circular flower beds.

[4 points]

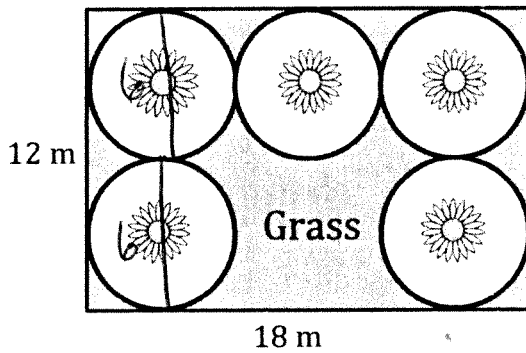

- a) What is the area of each flower bed?

$$\left(\frac{1}{2}\right) r = 3$$

$$\textcircled{1} A = \pi r^2 = 3.14 \times 3^2 = 28.26 \text{ m}^2$$

- b) How many square metres of **grass** are required to cover the **shaded area**?

$$\left(\frac{1}{2}\right) \text{ Rectangle Area} = b \times h = 18 \times 12 = 216 \text{ m}^2$$

$$\textcircled{1} 5 \text{ Circles} = 5(28.26) = 141.3 \text{ m}^2$$

$$\textcircled{1} \text{ Grass Area} = 216 - 141.3 = 74.7 \text{ m}^2$$

54. During one week in August, the highest temperature was recorded each day:

[2 points]

16°C , 23°C , 26°C , 28°C , 23°C , 27°C , 25°C

Calculate the **mean**, **median**, and **mode**.

$$\begin{aligned} \text{mean} &: (16 + 23 + 26 + 28 + 23 + 27 + 25) \div 7 \\ &= 168 \div 7 = 24 \end{aligned}$$

$$\text{median} : 16, 23, 23, 25, 26, 27, 28$$

$$\text{mode} : 23$$

Mean 24°C $\textcircled{1}$

Median 25°C $\textcircled{\frac{1}{2}}$

Mode 23°C $\textcircled{\frac{1}{2}}$

55. Draw $\angle ABC$ to measure 110° . Bisect the angle.

[2 points]

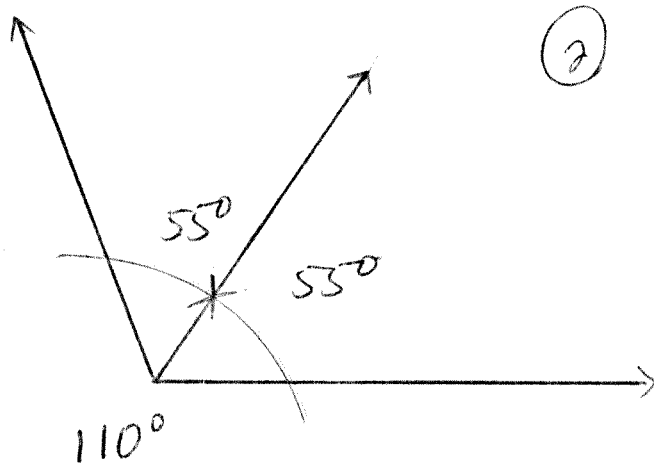

Compass
or
mira
or
paper folding
or
measure

56. a) Plot and label points A, B, and C to form a triangle.

[3 points]

$A(-3, 0)$ $B(-2, 6)$ $C(1, 4)$

b) Reflect $\triangle ABC$ in the x-axis. Label the image.

c) Translate $\triangle A'B'C'$ 6 units right and 3 units up. Label the final image.

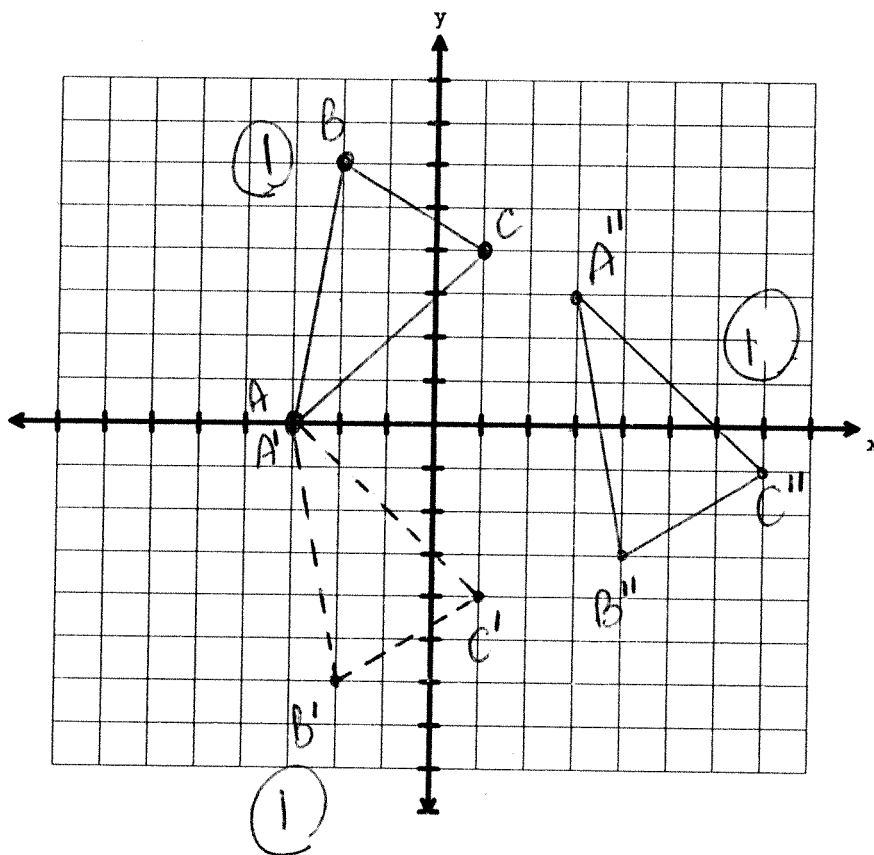

End of Grade 7 Common Mathematics Assessment.
Have a safe and happy summer!

Grade 7 Common Mathematics Assessment
Answer Sheet

Name: _____
Mathematics Teacher: _____
Homeroom: _____

Section A
No Calculator Permitted

1. (A) B C D
2. A B (C) D
3. A B C (D)
4. A (B) C D
5. A B C (D)
6. A (B) C D
7. A B C (D)
8. A B (C) D
9. (A) B C D
10. A B C (D)
11. A (B) C D
12. A B (C) D
13. A B C (D)
14. A (B) C D
15. A B C (D)
16. A (B) C D

Section B
Calculator Permitted

24. (A) B C D
25. A (B) C D
26. A B C (D)
27. A B C (D)
28. A B (C) D
29. A B C (D)
30. A B (C) D
31. A (B) C D
32. (A) B C D
33. A (B) C D
34. A B (C) D
35. A (B) C D
36. A B (C) D
37. (A) B C D
38. A B (C) D
39. (A) B C D
40. A B C (D)
41. A B C (D)
42. A B (C) D
43. (A) B C D
44. A B (C) D
45. A B (C) D
46. A (B) C D
47. A B C (D)